

1- 3/4" I.D. UMBRELLA HOLE

VINYLAST PLASTISOL TOP & SEATS
3/4" #9 EXPANDED METAL

SEAT MOUNTING ANGLES
1-3/4" X 1-3/4" X 3/16"
WELDED TO LEGS

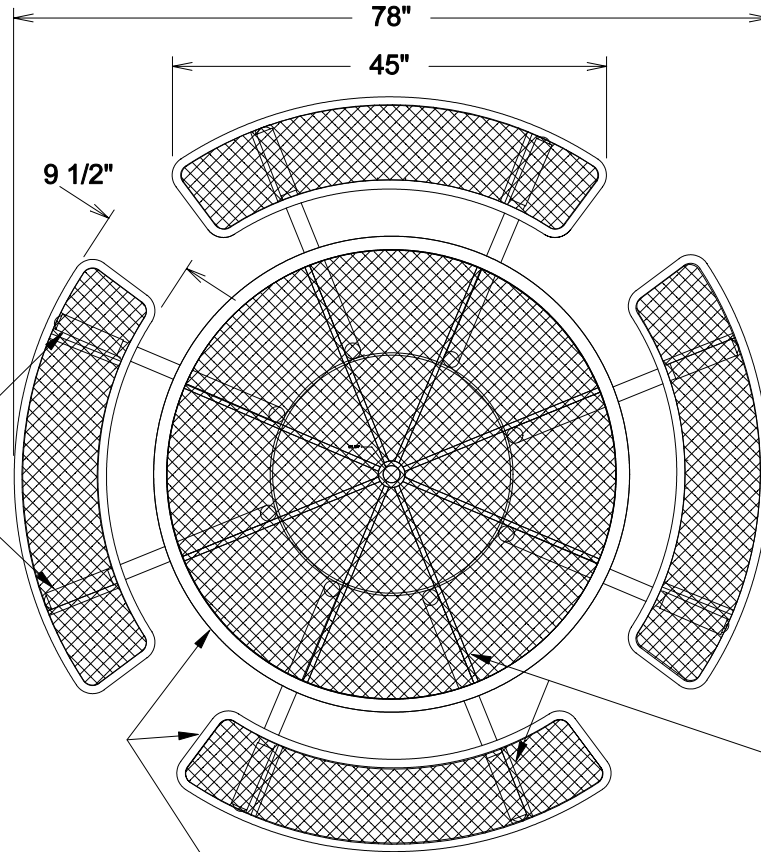
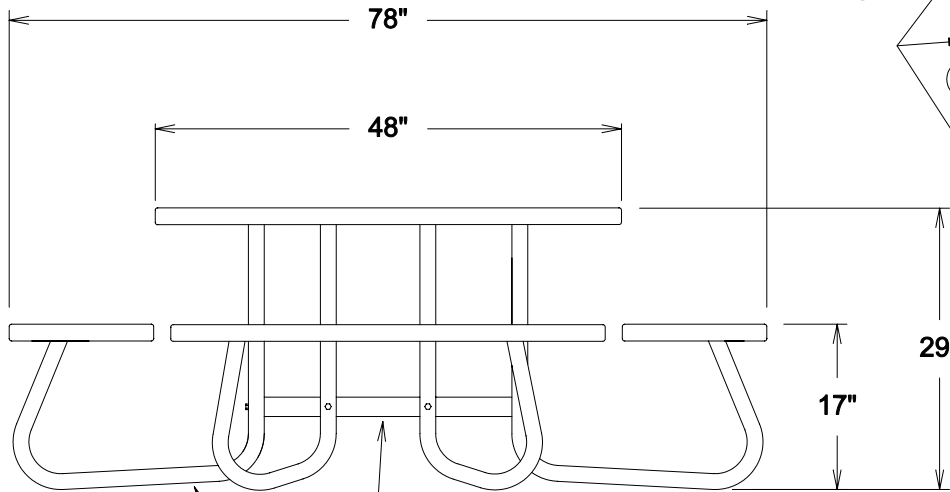

TOP AND SEAT STIFFENER
BARS 3/16" X 1-1/2" FLAT

TOP AND SEAT BORDERS
1-1/2" X 1/2" CHANNEL

* RTRCVP - POWDER COATED BLACK
RTRGVP - HOT DIPPED GALVANIZED

1-5/8" O.D. SCH. 40 PIPE
POWDER COATED BLACK OR
HOT DIPPED GALVANIZED
(BOTH COATINGS ARE AFTER FABRICATION)

CONNECTING RING
3/16" X 2" FLAT

FILE No. RTRVP Specs.

KAY PARK REC.

| | | |
|----------------------|-----------------|-----------------|
| MODEL SEE ABOVE * | | WT. 285 lbs. |
| DRAWN BY KLD | DATE 2/26/02 | SCALE NONE |